

Micro Motion® ELITE® Coriolis Flow and Density Sensors



Safety and approval information

This Micro Motion product complies with all applicable European directives when properly installed in accordance with the instructions in this manual. Refer to the EC declaration of conformity for directives that apply to this product. The EC declaration of conformity, with all applicable European directives, and the complete ATEX Installation Drawings and Instructions are available on the internet at www.micromotion.com or through your local Micro Motion support center.

Information affixed to equipment that complies with the Pressure Equipment Directive can be found on the internet at www.micromotion.com/documentation.

For hazardous installations in Europe, refer to standard EN 60079-14 if national standards do not apply.

Other information

Full product specifications can be found in the product data sheet. Troubleshooting information can be found in the transmitter configuration manual. Product data sheets and manuals are available from the Micro Motion web site at www.micromotion.com/documentation.

Return policy

Micro Motion procedures must be followed when returning equipment. These procedures ensure legal compliance with government transportation agencies and help provide a safe working environment for Micro Motion employees. Failure to follow Micro Motion procedures will result in your equipment being refused delivery.

Information on return procedures and forms is available on our web support system at www.micromotion.com, or by phoning the Micro Motion Customer Service department.

Micro Motion customer service

Email:

- Worldwide: flow.support@emerson.com
- Asia-Pacific: APflow.support@emerson.com

Telephone:

North and South America		Europe and Middle East		Asia Pacific	
United States	800-522-6277	U.K.	0870 240 1978	Australia	800 158 727
Canada	+1 303-527-5200	The Netherlands	+31 (0) 318 495 555	New Zealand	099 128 804
Mexico	+41 (0) 41 7686 111	France	0800 917 901	India	800 440 1468
Argentina	+54 11 4837 7000	Germany	0800 182 5347	Pakistan	888 550 2682
Brazil	+55 15 3413 8000	Italy	8008 77334	China	+86 21 2892 9000
Venezuela	+58 26 1731 3446	Central & Eastern	+41 (0) 41 7686 111	Japan	+81 3 5769 6803
		Russia/CIS	+7 495 981 9811	South Korea	+82 2 3438 4600
		Egypt	0800 000 0015	Singapore	+65 6 777 8211
		Oman	800 70101	Thailand	001 800 441 6426
		Qatar	431 0044	Malaysia	800 814 008
		Kuwait	663 299 01		
		South Africa	800 991 390		
		Saudia Arabia	800 844 9564		
		UAE	800 0444 0684		

Contents

Chapter 1	Planning	1
1.1	Installation checklist	1
1.2	Best practices	2
1.3	Temperature limits	3
1.4	Recommendations for hygienic and self-draining applications	6
Chapter 2	Mounting	8
2.1	Recommendations for lifting heavy meters	8
2.2	Mount the sensor	9
2.3	Mount electronics of high-temperature sensors	10
2.4	Mount a CMF010 sensor to a wall or pole	14
2.5	Mount a CMFS007, CMFS010 or CMFS015 sensor in a bracket	15
2.6	Mount a CMFS025, CMFS040 or CMFS050 sensor in a wall mount bracket	16
2.7	Secure wafer-style process connections	17
2.8	Attach extended electronics	19
Chapter 3	Wiring	21
3.1	Options for wiring	21
3.2	Connect 4-wire cable	22
3.3	Connect 9-wire cable	26
Chapter 4	Grounding	28
Chapter 5	Supplementary information	29
5.1	Purge the sensor case	29
5.2	About rupture disks	31

1 Planning

Topics covered in this chapter:

- [Installation checklist](#)
- [Best practices](#)
- [Temperature limits](#)
- [Recommendations for hygienic and self-draining applications](#)

1.1 Installation checklist

- Make sure that the hazardous area specified on the approval tag is suitable for the environment in which the meter will be installed.
- Verify that the local ambient and process temperatures are within the limits of the meter.
- If your sensor has an integral transmitter, no wiring is required between the sensor and transmitter. Follow the wiring instructions in the transmitter installation manual for signal and power wiring.
- If your transmitter has remote-mounted electronics, follow the instructions in this manual for wiring between the sensor and the transmitter, and then follow the instructions in the transmitter installation manual for power and signal wiring.
- For the wiring between the sensor and the transmitter, consider maximum cable lengths. The maximum distance between the sensor and transmitter depends on the cable type. For all types of wiring, Micro Motion recommends using Micro Motion cable.

Table 1-1: Maximum lengths for Micro Motion cable



Cable type	To transmitter	Maximum length
Micro Motion 9-wire	9739 MVD transmitter	1000 ft (300 m)
	All other MVD transmitters	60 ft (20 m)
Micro Motion 4-wire	All 4-wire MVD transmitters	1000 ft (300 m)

Table 1-2: Maximum lengths for user-supplied 4-wire cable

Wire function	Wire size	Maximum length
Power (VDC)	22 AWG (0,35 mm ²)	300 ft (90 m)
	20 AWG (0,5 mm ²)	500 ft (150 m)
	18 AWG (0,8 mm ²)	1000 ft (300 m)
Signal (RS-485)	22 AWG (0,35 mm ²) or larger	1000 ft (300 m)

- For optimal performance, install the sensor in the preferred orientation. The sensor will work in any orientation as long as the flow tubes remain full of process fluid.

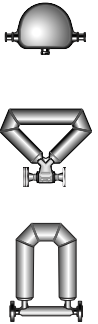
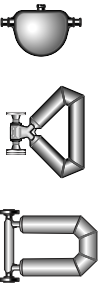
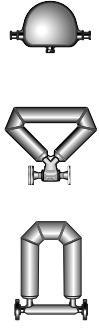
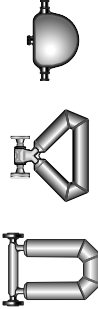
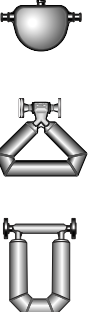
Table 1-3: Preferred sensor orientation

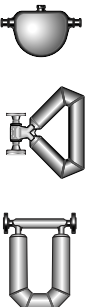
Process	Preferred orientation	Alternate orientations	
Liquids			
Gases			
Slurries			

- Install the meter so that the flow direction arrow on the sensor case matches the actual forward flow of the process. (Flow direction is also software-selectable.)

1.2 Best practices

The following information can help you get the most from your sensor.

- There are no pipe run requirements for Micro Motion sensors. Straight runs of pipe upstream or downstream are unnecessary.
- If the sensor is installed in a vertical pipeline, liquids and slurries should flow upward through the sensor. Gases may flow upward or downward.
- Keep the sensor tubes full of process fluid.
- For halting flow through the sensor with a single valve, install the valve downstream from the sensor.
- Minimize bending and torsional stress on the meter. Do not use the meter to align misaligned piping.
- The sensor does not require external supports. The flanges will support the sensor in any orientation. (Some sensor models installed in very small, flexible pipeline have optional installation instructions that allow for external supports.)

1.3 Temperature limits

- Sensors can be used in the process and ambient temperature ranges shown in the temperature limit graphs. For the purposes of selecting electronics options, temperature limit graphs should be used only as a general guide. If your process conditions are close to the gray areas, it may be inappropriate to use electronics options other than a junction box. Consult with your Micro Motion representative.
- In all cases, the electronics cannot be operated where the ambient temperature is below -40°F (-40°C) or above $+140^{\circ}\text{F}$ ($+60^{\circ}\text{C}$). If a sensor is to be used where the ambient temperature is outside of the range permissible for the electronics, the electronics must be remotely located where the ambient temperature is within the permissible range, as indicated by the shaded area of the temperature limit graphs.
- Temperature limits may be further restricted by hazardous area approvals. Refer to the hazardous area approvals documentation shipped with the sensor or available from the Micro Motion web site (www.micromotion.com).
- The extended-mount electronics option allows the sensor case to be insulated without covering the transmitter, core processor, or junction box, but does not affect temperature ratings.

Figure 1-1: Ambient and process temperature limits for ELITE CMF*M/L/H/P (excludes cryogenic modifications) and CMFS007-015 meters**

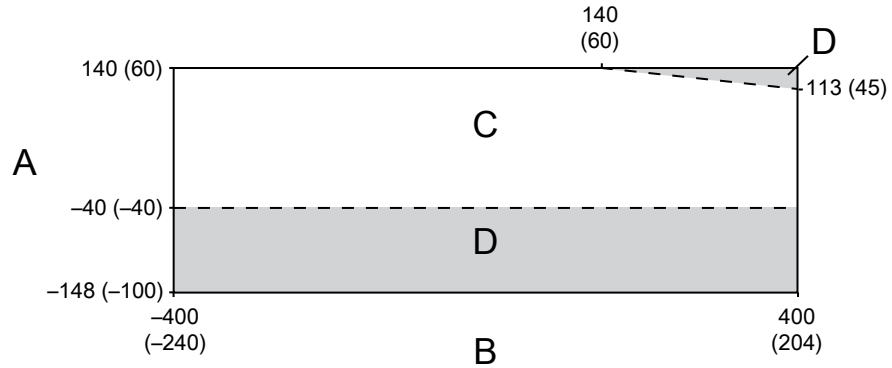

- A. Ambient temperature °F (°C)
- B. Process temperature in °F (°C)
- C. All available electronic options
- D. Extended or remote mount electronics only

Figure 1-2: Ambient and process temperature limits for ELITE CMFS025–CMFS150 meters

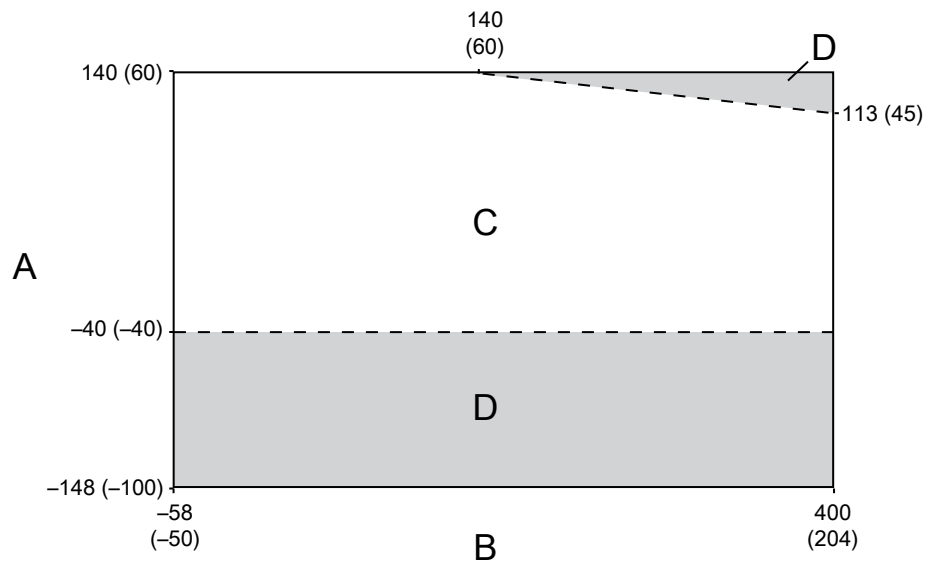

- A. Ambient temperature °F (°C)
- B. Process temperature in °F (°C)
- C. All available electronic options
- D. Extended or remote mount electronics only

Figure 1-3: Ambient and process temperature limits for cryogenic ELITE meters

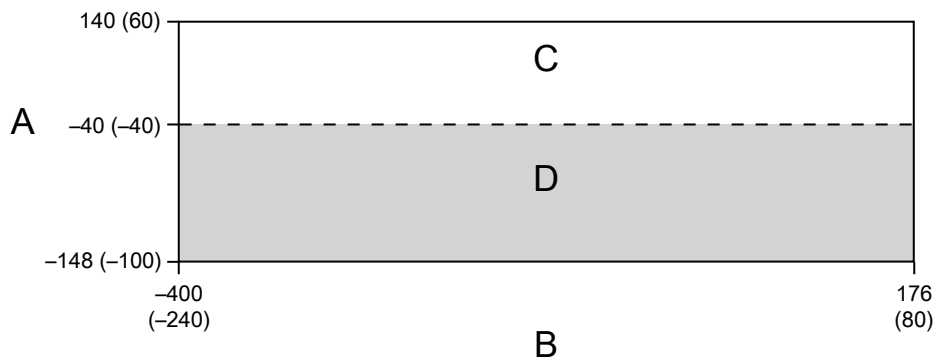

- A. Ambient temperature °F (°C)
- B. Process temperature in °F (°C)
- C. All available electronic options
- D. Extended or remote mount electronics only

Figure 1-4: Ambient and process temperature limits for high temperature ELITE meters

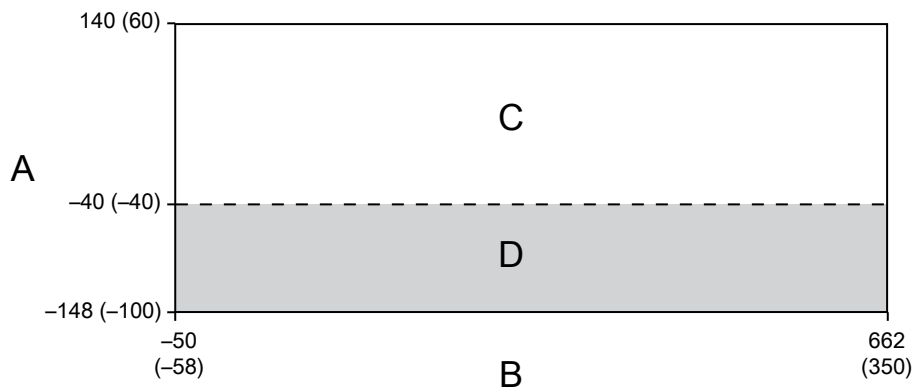

- A. Ambient temperature °F (°C)
- B. Process temperature in °F (°C)
- C. All available electronic options
- D. Extended or remote mount electronics only

Figure 1-5: Ambient and process temperature limits for Super Duplex ELITE meters

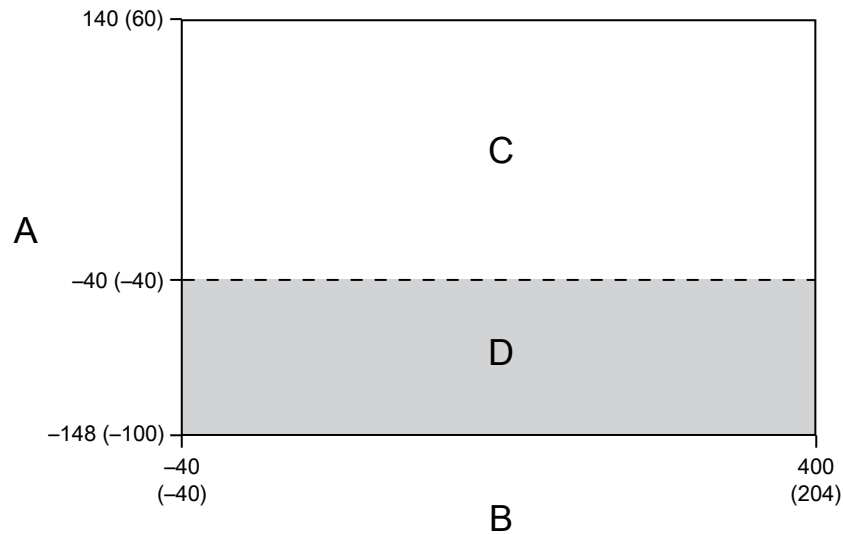

- A. Ambient temperature °F (°C)
- B. Process temperature in °F (°C)
- C. All available electronic options
- D. Extended or remote mount electronics only

1.4 Recommendations for hygienic and self-draining applications

CMFS sensors are certified EHEDG TYPE EL CLASS I for hygienic applications when installed vertically with the process fitting and gasket combinations listed in the Position Paper of the EHEDG Test Methods Subgroup (available at <http://www.ehedg.org>). Other process connections/gasket combinations may be used provided they have been evaluated and successfully tested for in-place cleanability according to the latest edition of EHEDG Document 2. Refer to the ELITE Product Data Sheet for further information about fitting options.

For optimal cleanability and drainability:

- If possible, install the sensor in a vertical pipeline with the process fluid flowing upward through the sensor.
- If the sensor must be installed in a horizontal pipeline, drainage is accomplished by air purge evacuation of the pipeline circuit.
- For clean-in-place (CIP) applications, Micro Motion recommends using the generally-accepted flow velocity of at least 1.5 m/s for cleaning the sensor.
- The gap between the electronics housing and sensor body should be inspected periodically. Manually clean this gap when necessary.

Figure 1-6: Installation for self-draining applications

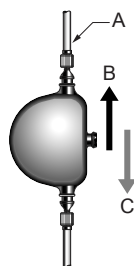

- A. *Process pipeline*
- B. *Direction of normal process flow*
- C. *Direction of drainage*

2 Mounting

Topics covered in this chapter:

- *Recommendations for lifting heavy meters*
- *Mount the sensor*
- *Mount electronics of high-temperature sensors*
- *Mount a CMF010 sensor to a wall or pole*
- *Mount a CMFS007, CMFS010 or CMFS015 sensor in a bracket*
- *Mount a CMFS025, CMFS040 or CMFS050 sensor in a wall mount bracket*
- *Secure wafer-style process connections*
- *Attach extended electronics*

2.1 Recommendations for lifting heavy meters

Heavy meters (those over 50 lb. [22 kg]), and even lighter meters that must be installed in elevated or difficult-to-reach places, usually require additional consideration when transporting or lifting them into their installation location.

- Safe handling during transportation and installation is the responsibility of the installer – know and follow all safety practices and regulations for your facility and for any lifting/rigging equipment being used
- A professional rigging crew with proper equipment should be used
- Typical equipment for handling heavy meters includes the following:
 - Fixed hoist boom trucks or cranes
 - Continuous web belt slings
 - Eye to eye web belt slings
 - Two leg wire rope slings
- Lift a meter by its case or on the case side of its process fittings.
- Do not lift a meter by its electronics (junction box, transmitter, or any electrical fittings) or by its purge fittings
- It may be useful to identify the meter center of gravity
- Protect the sealed surfaces on the process fittings with factory-installed flange protectors or comparable field-installed protection

Figure 2-1: Acceptable lifting points

Figure 2-2: Center of gravity for large meters

A. Typical center of gravity

Note

Complete and detailed dimensional drawings, including the location of the center of gravity, can be found through the product drawings link in our online store (www.micromotion.com/onlinestore).

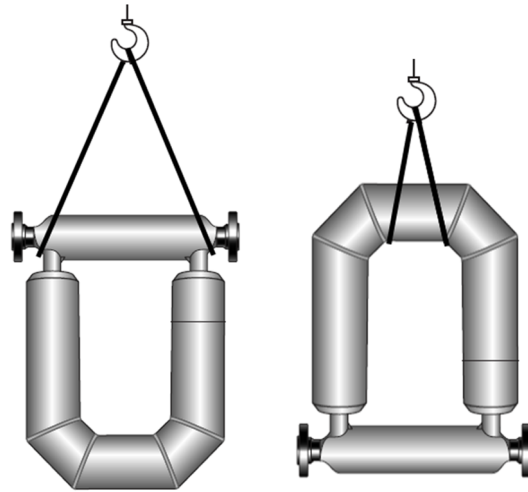
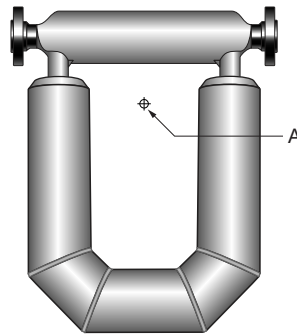
2.2 Mount the sensor

Use your common practices to minimize torque and bending load on process connections.

Tip

To reduce the risk of condensation or excessive moisture, the conduit opening should not point upward (if possible). The conduit opening of the junction box or core processor can be rotated freely to facilitate wiring.

⚠ CAUTION!

Do not lift the sensor by the electronics or purge connections. Lifting the sensor by the electronics or purge connections can damage the device.

Figure 2-3: Mounting the sensor

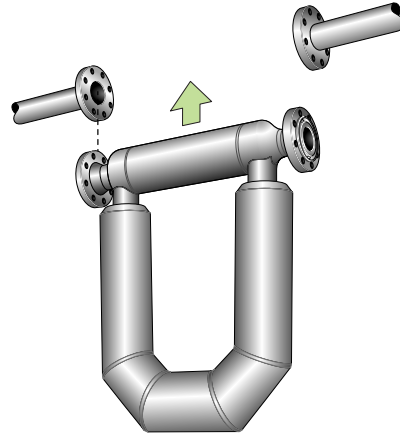

Notes

- Do not use the sensor to support the piping.
- The sensor does not require external supports. The flanges will support the sensor in any orientation. (Some sensor models installed in very small, flexible pipeline have optional installation instructions that allow for external supports.)

2.3 Mount electronics of high-temperature sensors

The electronics of high-temperature sensors are attached to the end of a 32" (812 mm) pre-installed flexible conduit. The electronics must be separately mounted on a wall or instrument pole.

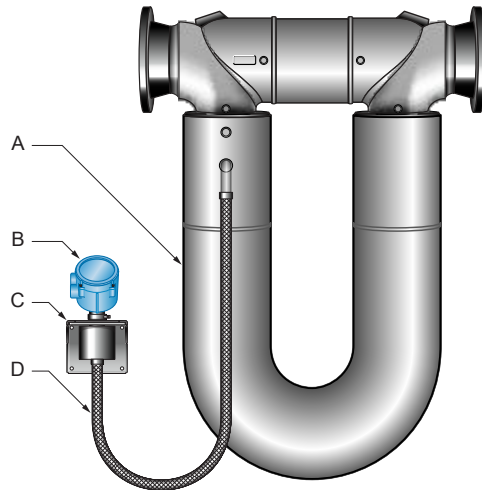
Figure 2-4: Components of a high-temperature sensor

- A. *Sensor*
- B. *Electronics*
- C. *Mounting bracket*
- D. *Flexible conduit (minimum bend radius 6" [152 mm])*

With some large meter sizes, the meter may ship with the electronics attached to the sensor case. The meter cannot be operated in this configuration. Detach the electronics bracket from the sensor case and then proceed to mount the electronics to a wall or instrument pole as described below.

Important

Do not operate the meter while the electronics are attached to the sensor case.

Figure 2-5: Removing electronics from the sensor case

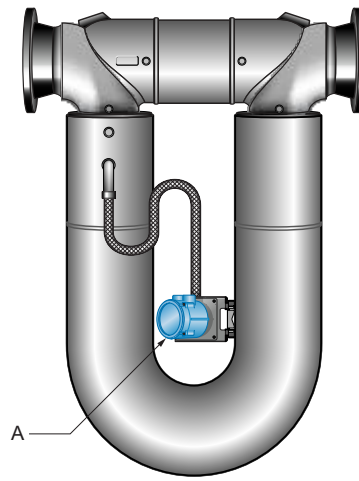

A. *Detach electronics from sensor case and mount to a wall or instrument pole*

Procedure

- For wall mounting, use four 5/16" or four M8 bolts to secure the mounting bracket.

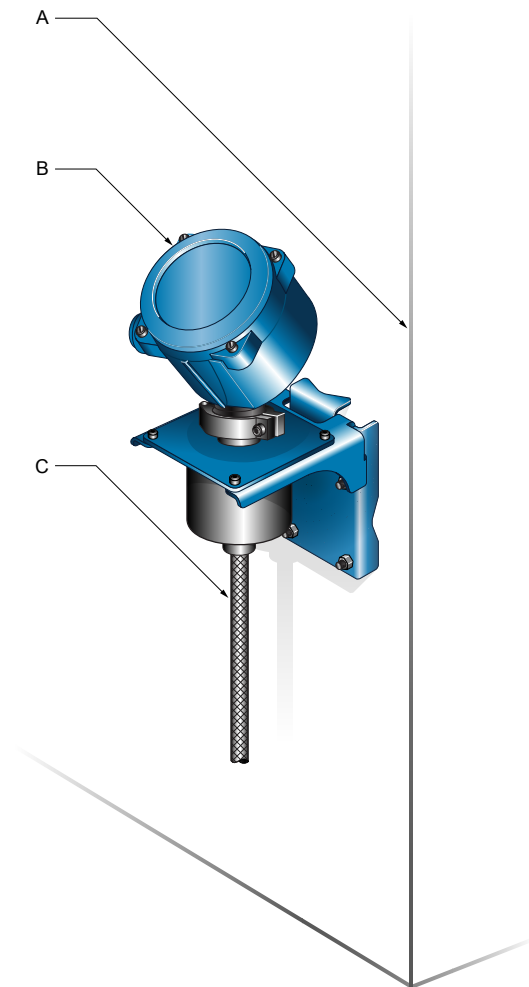
Figure 2-6: Wall-mount components

- A. Wall or flat surface
- B. Electronics (enhanced core processor shown)
- C. Flexible conduit

- For mounting to an instrument pole, use a 2-inch U-bolt pipe kit to secure the mounting bracket.

Figure 2-7: Pole-mount components

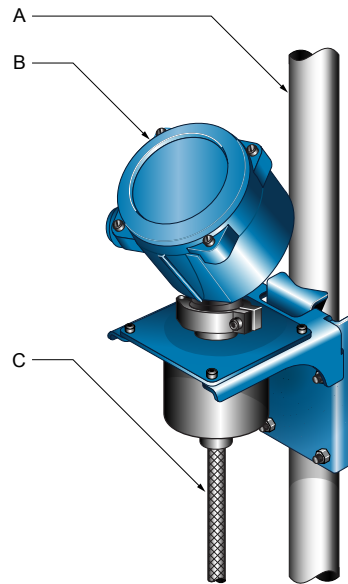

- A. Instrument pole
 - B. Electronics (enhanced core processor shown)
 - C. Flexible conduit
-

2.4 Mount a CMF010 sensor to a wall or pole

The CMF010 sensor has an optional mounting configuration for use with small or flexible pipeline. If the pipeline adequately supports the sensor, this procedure can be skipped.

1. Locate the optional mounting holes. For sensors with a junction box, the junction box must be rotated to the side to expose the mounting holes.

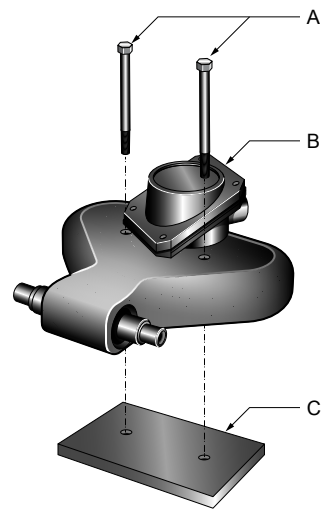
Figure 2-8: Optional mounting for CMF010 sensors

- A. *Two user-supplied 5/16" (M8) bolts*
- B. *Junction box or core processor (junction box shown)*
- C. *Mounting surface*

2. If necessary, install rigid standoffs between the sensor and the mounting surface.
3. Using two user-supplied 5/16" (M8) bolts (minimum length 2 1/4" [58 mm]), secure the sensor case to the mounting surface.

2.5 Mount a CMFS007, CMFS010 or CMFS015 sensor in a bracket

The CMFS007, CMFS010 and CMFS015 sensors have an optional mounting bracket for use with small or flexible pipeline. If the pipeline adequately supports the sensor, this procedure can be skipped.

1. Secure the mounting bracket to a wall or other flat surface with four user-supplied 5/16" (8 mm) bolts.
2. Place the sensor into the bracket.
3. Secure the sensor in the bracket with the supplied 5/16" (M8) U-bolts.

Figure 2-9: Mounting bracket for CMFS007, CMFS010, and CMFS015

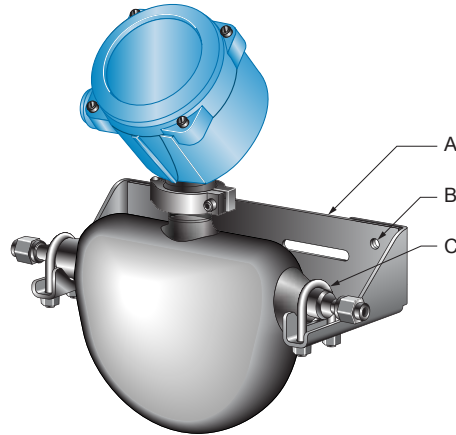

- A. Mounting bracket
 - B. Mounting holes
 - C. Supplied U-bolts
-

2.6 Mount a CMFS025, CMFS040 or CMFS050 sensor in a wall mount bracket

The CMFS025, CMFS040, and CMFS050 sensors have an optional wall mounting bracket.

1. Assemble the bracket.

Figure 2-10: Assembled wall mounting bracket for CMFS025, CMFS040, and CMFS050

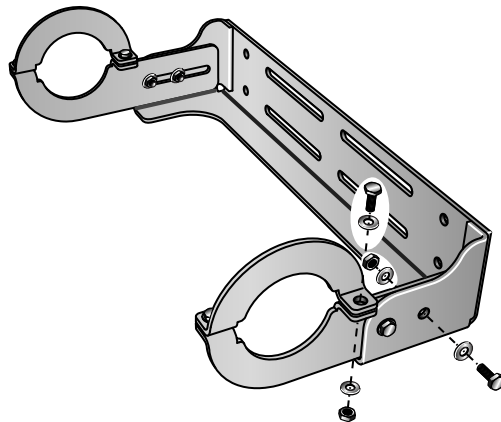

2. Attach the bracket to the wall using fasteners appropriate for the mounting surface.

3. Place the sensor into the bracket.
4. Secure the sensor in the bracket with the supplied fasteners.

Figure 2-11: CMFS025, CMFS040, or CMFS050 wall mounted using bracket



2.7 Secure wafer-style process connections

A wafer-style connection lets you clamp the sensor into the pipeline. A wafer installation kit is shipped with a wafer-style sensor.

1. Make sure that the bolts provided are rated for your process connection.
2. Slip the sensor alignment rings over each end of the sensor wafer, then insert the sensor between the process connections in the pipeline.

Tip

Micro Motion recommends installing gaskets (user-supplied).

Figure 2-12: Wafer-style connection components

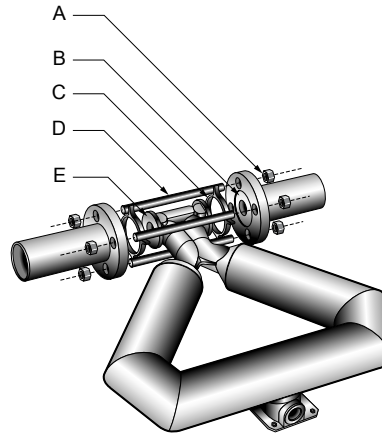

- A. Flange nut
- B. Gasket (user-supplied)
- C. Alignment ring
- D. Flange bolt
- E. Sensor wafer

3. Insert the flange bolts through both process connections, and thread the flange nuts onto the bolts.
4. With your fingers, tighten the flange nuts.
5. Rotate the sensor alignment rings in the direction that pushes the bolts outward.

Tip

Rotate both sensor alignment rings until the assembly is centered and tight.

Figure 2-13: Alignment ring usage

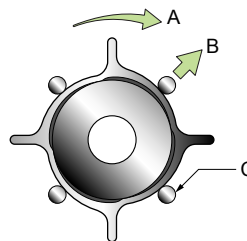

- A. Direction to rotate the alignment ring
- B. Direction the flange bolts are pushed
- C. Flange bolt

6. With a wrench, tighten the nuts in an alternating order.

2.8 Attach extended electronics

If you ordered a sensor with extended electronics, you will need to install the extender onto the sensor case.

Note

Extended core processors are matched at the factory to specific sensors. Keep each core processor together with the sensor with which it was shipped.

CAUTION!

Keep the extender and feedthrough clean and dry. Moisture or debris in the extender or feedthrough can damage electronics and result in measurement error or flowmeter failure.

Procedure

1. Remove and recycle the plastic cap from the feedthrough on the sensor.

Figure 2-14: Feedthrough and extender components

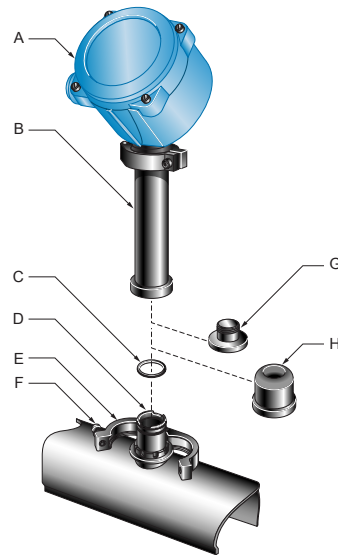

- A. *Transmitter or core processor*
- B. *Extender*
- C. *O-ring*
- D. *Feedthrough*
- E. *Clamping ring*
- F. *Clamping screw*
- G. *Plastic plug*
- H. *Plastic cap*

2. Loosen the clamping screw and remove the clamping ring. Leave the O-ring in place on the feedthrough.
3. Remove and recycle the plastic plug from the extender.
4. Fit the extender onto the feedthrough by carefully aligning the notches on the bottom of the extender with the notches on the feedthrough.
5. Close the clamping ring and tighten the clamping screw to 13–18 in-lbs. (1,5–2 N-m).

3 Wiring

Topics covered in this chapter:

- [Options for wiring](#)
- [Connect 4-wire cable](#)
- [Connect 9-wire cable](#)

3.1 Options for wiring

The wiring procedure you follow depends on which electronics option you have.

Table 3-1: Wiring procedures by electronics option

Electronics option	Wiring procedure
Integral transmitter	No wiring is required between sensor and transmitter. See the transmitter installation manual for wiring the power and signal cable to the transmitter.
MVD™ Direct Connect™	No transmitter to wire. See the MVD Direct Connect manual for wiring the power and signal cable between the sensor and the direct host.
Core processor	Connect a 4-wire cable between the sensor and transmitter. Refer to the 4-wire connection instructions in this manual.
Junction box	Connect a 9-wire cable between the sensor and transmitter. Refer to the 9-wire connection instructions in this manual, as well as the <i>Micro Motion 9-Wire Flowmeter Cable Preparation and Installation Guide</i> .

⚠ CAUTION!

Make sure the hazardous area specified on the sensor approval tag is suitable for the environment in which the sensor will be installed. Failure to comply with the requirements for intrinsic safety in a hazardous area could result in an explosion.

⚠ CAUTION!

Fully close and tighten all housing covers and conduit openings. Improperly sealed housings can expose electronics to moisture, which can cause measurement error or flowmeter failure. Inspect and grease all gaskets and O-rings.

3.2 Connect 4-wire cable

3.2.1 Prepare the 4-wire cable

Important

For user-supplied cable glands, the gland must be capable of terminating the drain wires.

Note

If you are installing unshielded cable in continuous metallic conduit with 360° termination shielding, you only need to prepare the cable – you do not need to perform the shielding procedure.

Figure 3-1: 4-wire cable preparation

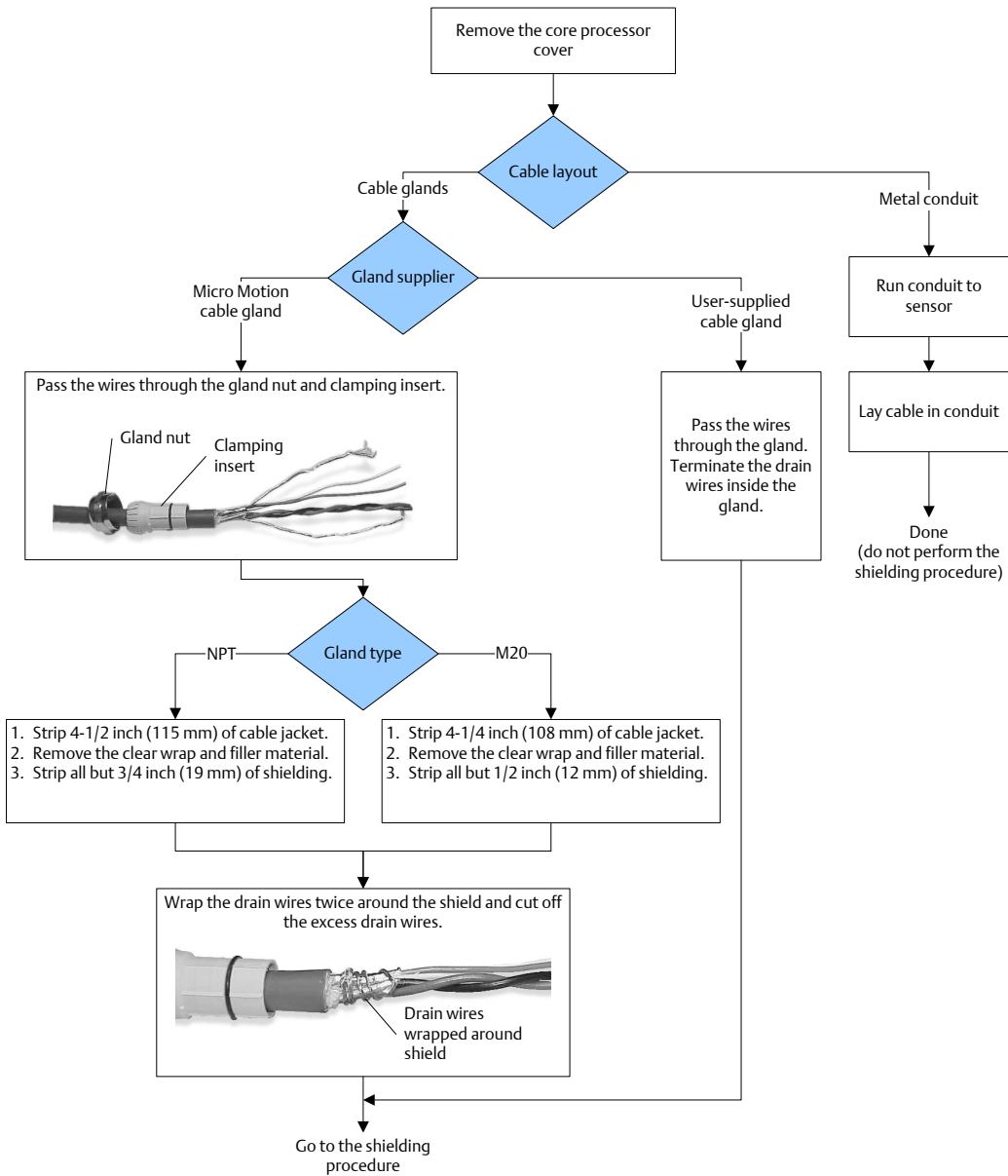
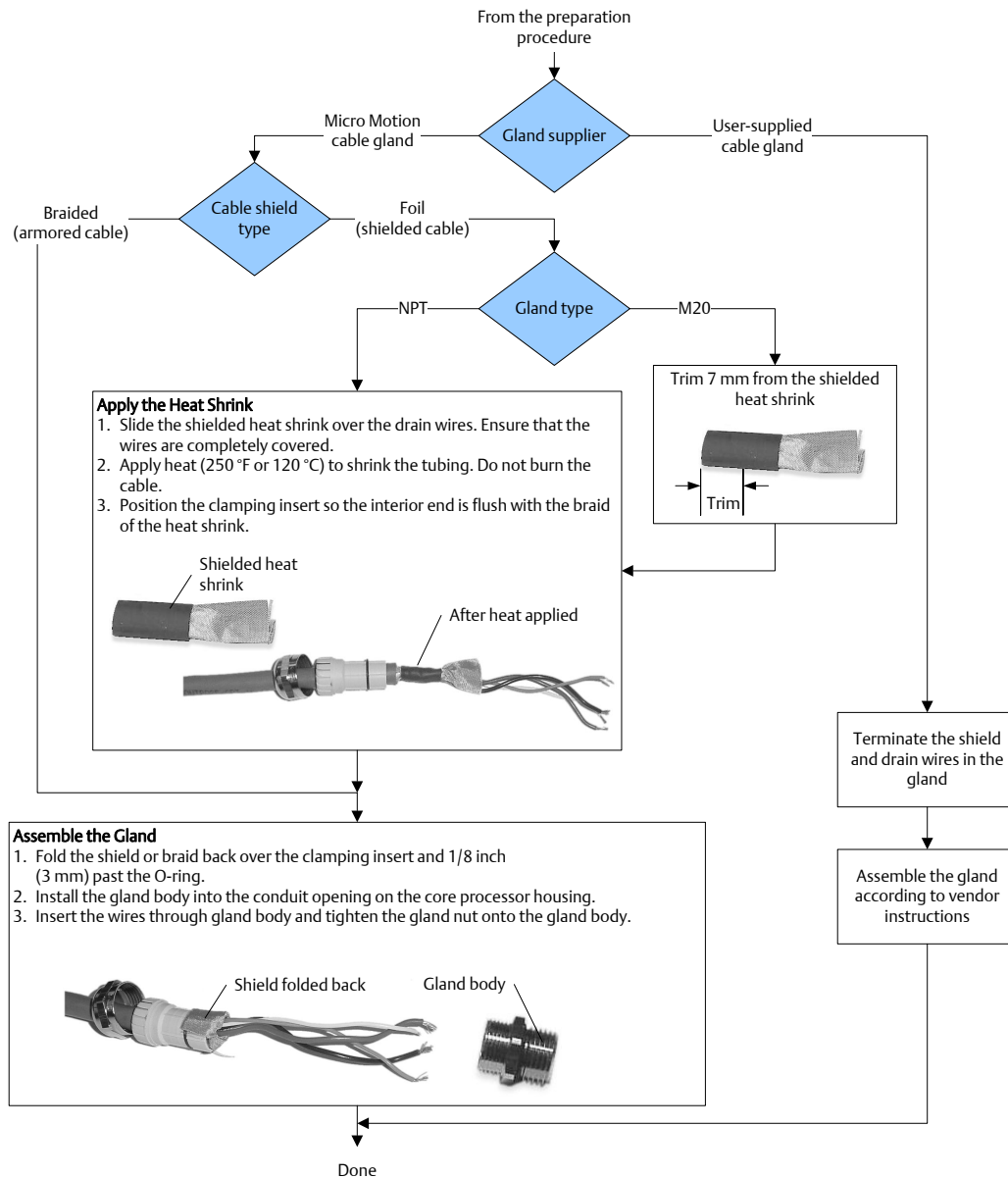

Figure 3-2: 4-wire cable shielding



4-wire cable types and usage

Micro Motion offers two types of 4-wire cable: shielded and armored. Both types contain shield drain wires.

The 4-wire cable supplied by Micro Motion consists of one pair of red and black 18 AWG (0.75 mm²) wires for the VDC connection, and one pair of white and green 22 AWG (0.35 mm²) wires for the RS-485 connection.

User-supplied 4-wire cable must meet the following requirements:

- Twisted pair construction.
- Applicable hazardous area requirements, if the core processor is installed in a hazardous area.
- Wire gauge appropriate for the cable length between the core processor and the transmitter.

Table 3-2: Wire gauge

Wire gauge	Maximum cable length
VDC 22 AWG (0.35 mm ²)	300 ft (90 m)
VDC 20 AWG (0.5 mm ²)	500 ft (150 m)
VDC 18 AWG (0.8 mm ²)	1000 ft (300 m)
RS-485 22 AWG (0.35 mm ²) or larger	1000 ft (300 m)

3.2.2 Connect the wires to the core processor terminals

After the 4-wire cable has been prepared and shielded (if required), connect the individual wires of the 4-wire cable to the terminals on the core processor.

Figure 3-3: Core processor terminals

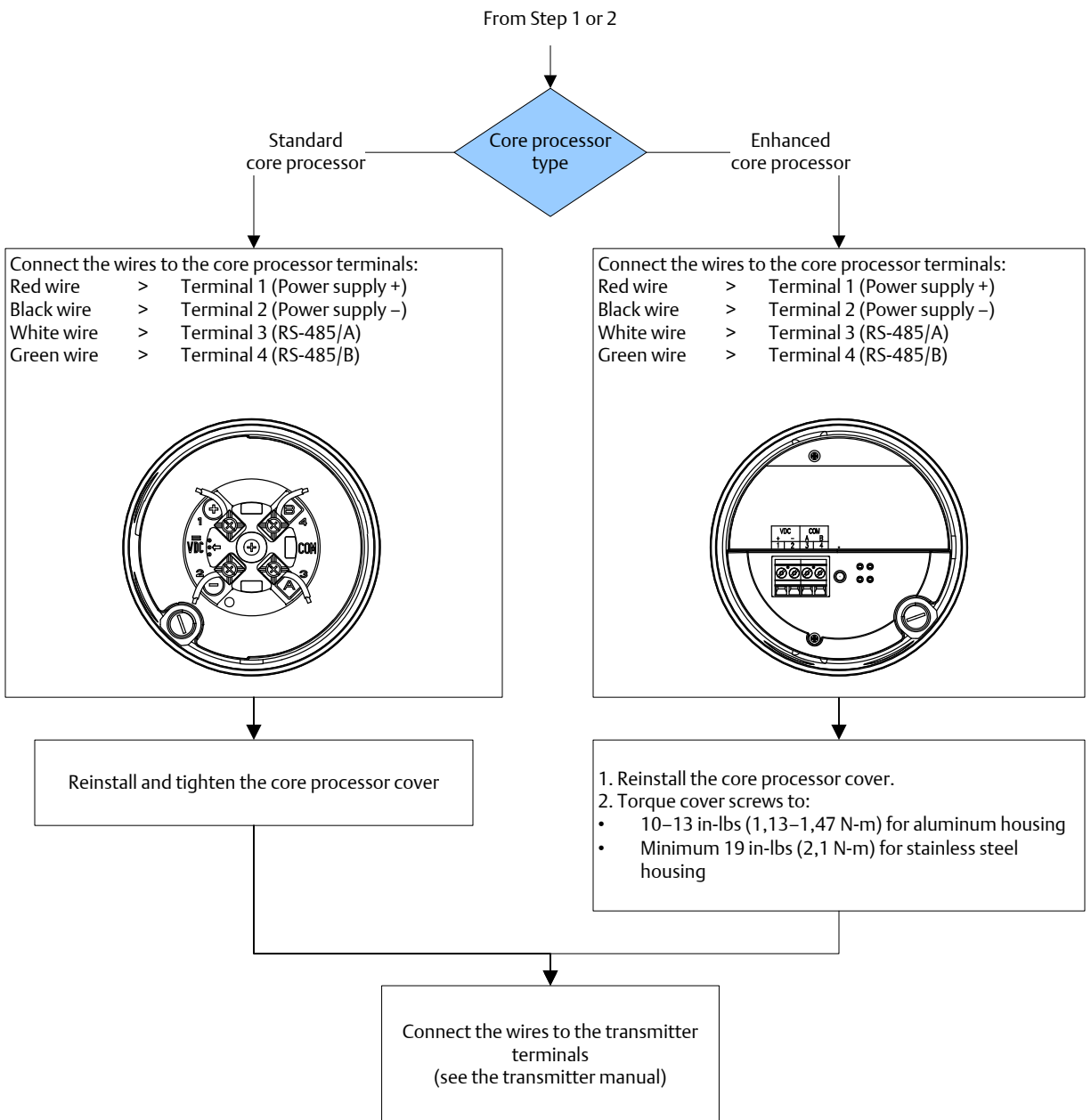

3.3 Connect 9-wire cable

1. Prepare and install the cable according to the instructions in the *Micro Motion 9-Wire Flowmeter Cable Preparation and Installation Guide*.
2. Insert the stripped ends of the individual wires into the terminal blocks. Ensure that no bare wires remain exposed.

3. Match the wires color for color. For wiring at the transmitter or remote core processor, refer to the transmitter documentation.
4. Tighten the screws to hold the wires in place.
5. Ensure integrity of gaskets, then tightly close and seal the junction box cover and all housing covers on the transmitter or core processor.
6. Refer to the transmitter installation manual for signal and power wiring instructions.

4 Grounding

The meter must be grounded according to the standards that are applicable at the site. The customer is responsible for knowing and complying with all applicable standards.

Prerequisites

Micro Motion suggests the following guides for grounding practices:

- In Europe, IEC 79-14 is applicable to most installations, in particular Sections 12.2.2.3 and 12.2.2.4.
- In the U.S.A. and Canada, ISA 12.06.01 Part 1 provides examples with associated applications and requirements.

If no external standards are applicable, follow these guidelines to ground the sensor:

- Use copper wire, 14 AWG (2,0 mm²) or larger wire size.
- Keep all ground leads as short as possible, less than 1 Ω impedance.
- Connect ground leads directly to earth, or follow plant standards.

CAUTION!

Ground the flowmeter to earth, or follow ground network requirements for the facility. Improper grounding can cause measurement error.

Procedure

Check the joints in the pipeline.

- If the joints in the pipeline are ground-bonded, the sensor is automatically grounded and no further action is necessary (unless required by local code).
- If the joints in the pipeline are not grounded, connect a ground wire to the grounding screw located on the sensor electronics.

Tip

The sensor electronics may be a transmitter, core processor, or junction box. The grounding screw may be internal or external.

5 Supplementary information

Topics covered in this chapter:

- [Purge the sensor case](#)
- [About rupture disks](#)

5.1 Purge the sensor case

If the sensor has purge fittings, they should remain sealed at all times. After a purge plug has been removed, the sensor case should be purged with argon or nitrogen and resealed.

Purging the case protects internal components. The sensor is purged of all oxygen and sealed at the factory. If the purge plugs are never removed, it is not necessary to purge or re-seal the sensor. For more information, contact Micro Motion Customer Service.

If a purge plug is removed from the sensor case, it will be necessary to repurge the case.

CAUTION!

Take all necessary precautions when removing purge plugs. Removing a purge plug compromises the secondary containment of the sensor and could expose the user to process fluid.

CAUTION!

Improper pressurization of the sensor case could result in personal injury. Removing a purge plug will require the sensor case to be repurged with a dry inert gas. Follow all instructions provided in the case purging procedure.

Prerequisites

Make sure the following are available before beginning the purge procedure:

- Teflon[®] tape
- Argon or nitrogen gas sufficient to purge the sensor case

Procedure

1. Shut down the process, or set control devices for manual operation. Before performing the case purging procedure, shut down the process or set the control devices for manual operation. Performing the purge procedure while the flowmeter is operating could affect measurement accuracy, resulting in inaccurate flow signals.
2. Remove both purge plugs from the sensor case. If purge lines are being used, open the valve in the purge lines.
3. Prepare the purge plugs for reinstallation by wrapping them with 3–5 turns of Teflon tape.

4. Connect the supply of nitrogen or argon gas to the inlet purge connection or open inlet purge line. Leave the outlet connection open.
 - Exercise caution to avoid introducing dirt, moisture, rust, or other contaminants into the sensor case.
 - If the purge gas is heavier than air (such as argon), locate the inlet lower than the outlet, so that the purge gas will displace air from bottom to top.
 - If the purge gas is lighter than air (such as nitrogen), locate the inlet higher than the outlet, so that the purge gas will displace air from top to bottom.
5. Make sure that there is a tight seal between the inlet connection and sensor case, so that air cannot be drawn by suction into the case or purge line during the purging process.
6. Run purge gas through the sensor.

The purge time is the amount of time required for full exchange of atmosphere to inert gas. The larger the line size, the greater amount of time is required to purge the case. If purge lines are being used, increase the purge time to fill the additional volume of the purge line.

Note

Keep the purge gas pressure below 30 psig (2 bar).

Table 5-1: Purge time

Sensor model	Purge rate, in ft ³ /hr (l/h)	Time, in minutes
CMF010	20 (566)	1
CMF025	20 (566)	1
CMF050	20 (566)	2
CMF100	20 (566)	5
CMF200	20 (566)	12
CMF300	20 (566)	30
CMF350	20 (566)	45
CMF400	20 (566)	55
CMFHC2	20 (566)	100
CMFHC3	20 (566)	170
CMFHC4	20 (566)	268
CMFS007	20 (566)	1 1/2
CMFS010	20 (566)	1 1/2
CMFS015	20 (566)	1 1/2
CMFS025	20 (566)	4 1/2
CMFS040	20 (566)	4 1/2
CMFS050	20 (566)	4 1/2
CMFS075	20 (566)	6

Table 5-1: Purge time (continued)

Sensor model	Purge rate, in ft ³ /hr (l/h)	Time, in minutes
CMFS100	20 (566)	6
CMFS150	20 (566)	6

- At the appropriate time, shut off the gas supply, then immediately seal the purge outlet and inlet connections with the purge plugs.

Note

Avoid pressurizing the sensor case. If pressure inside the case elevates above atmospheric pressure during operation, the flowmeter density calibration will be inaccurate.

- Make sure that the purge fitting seals are tight so that air cannot be drawn by suction into the sensor case.

5.2 About rupture disks

Rupture disks are meant to vent process fluid from the sensor case in the event of a flow tube rupture. Some users connect a pipeline to the rupture disk to help contain escaping process fluid. For more information about rupture disks, contact Micro Motion Customer Service.

If the sensor has rupture disks, they are installed in the sensor purge fitting openings. The rupture disks should remain installed at all times. If you remove a rupture disk from the sensor case, it will be necessary to re-purge the case.

⚠ CAUTION!

Stay clear of the rupture disk pressure relief area. High-pressure fluid escaping from the sensor can cause severe injury or death.



20002158

Rev DI

2014

Micro Motion Inc. USA

Worldwide Headquarters
7070 Winchester Circle
Boulder, Colorado 80301
T +1 303-527-5200
T +1 800-522-6277
F +1 303-530-8459
www.micromotion.com

Micro Motion Europe

Emerson Process Management
Neonstraat 1
6718 WX Ede
The Netherlands
T +31 (0) 318 495 555
F +31 (0) 318 495 556
www.micromotion.nl

Micro Motion Asia

Emerson Process Management
1 Pandan Crescent
Singapore 128461
Republic of Singapore
T +65 6777-8211
F +65 6770-8003

Micro Motion United Kingdom

Emerson Process Management Limited
Horsfield Way
Bredbury Industrial Estate
Stockport SK6 2SU U.K.
T +44 0870 240 1978
F +44 0800 966 181

Micro Motion Japan

Emerson Process Management
1-2-5, Higashi Shinagawa
Shinagawa-ku
Tokyo 140-0002 Japan
T +81 3 5769-6803
F +81 3 5769-6844

©2014 Micro Motion, Inc. All rights reserved.

The Emerson logo is a trademark and service mark of Emerson Electric Co. Micro Motion, ELITE, ProLink, MVD and MVD Direct Connect marks are marks of one of the Emerson Process Management family of companies. All other marks are property of their respective owners.

